

Owner's Manual  
Type AGS  
Aquatape™ Gauging System

M267 Rev F

June 18, 2004

**JOWA Consilium**

JOWA Consilium US, Inc.  
59 Porter Road  
Littleton, MA 01460-1431 USA  
Tel: 978-486-9800  
Fax: 978-486-0170

# OWNER'S MANUAL

## AQUATAPE™ GAUGING SYSTEM

### 1. INTRODUCTION

This manual sets forth the principles, properties and methods of utilizing the Aquatape Gauging System. We believe you will find Aquatape to be a good solution to your water-level gauging requirements. If you need further information or application assistance, please contact the JOWA Consilium factory, or the nearest sales office.

### 2. AQUATAPE APPLICATION

Aquatape Gauging System, Type AGS -

- (a) Is for measurement of *water* levels, including fresh and salt water, municipal wastewater and sewage, and water-based slurries and suspensions.
- b) Serves such environmental applications as water holding tanks, sumps, ponds, rivers, streams, sewers, reservoirs and ocean sites.
- c) Is *not* designed for petroleum, chemicals or solvents, or for pressurized or heated tanks. (See other JOWA Consilium sensor types.)

Please follow these simple installation and operating instructions. Use care to guard the exposed sensor from sharp objects until it is safely within its smooth-walled still pipe.

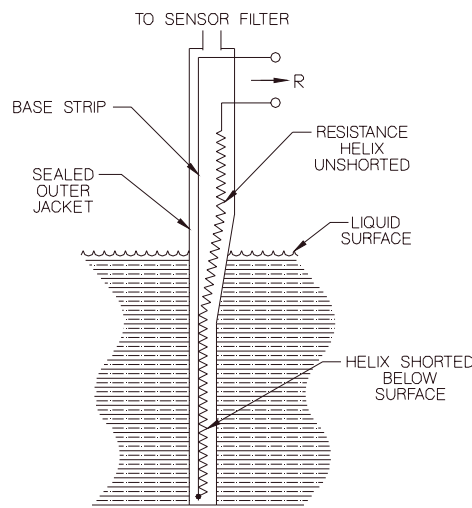

Figure 1 Sensor Operation

### 3 AQUATAPE SENSOR OPERATION

Aquatape sensor is an elongated resistance tape, which utilizes a continuous, helical resistance element enclosed within a sealed and compliant polymer sheath. Without hydrostatic pressure of liquid acting on the sheath, the resistance helix is unshorted down to the welded contact at the sensor bottom end, and full helix resistance appears across leadwires at the sensor top. Figure 1 shows that -

- (a) As liquid level rises, helix turns are progressively shorted against underlying base strip, reducing sensor resistance R to near zero at full tank condition; and
- (b) As liquid level falls, outer sheath and helix contacts are relieved of pressure and open, increasing sensor resistance R for each unit decrease in liquid level.
- (c) Responding to liquid pressure, sensor helix turns are shorted to within a short distance below the liquid surface. This distance, called Actuation Depth AD, is due to designed spring rate of sensor jacket and helix system; it is uniform throughout sensor length and is about 0.4 foot (or 125 mm).

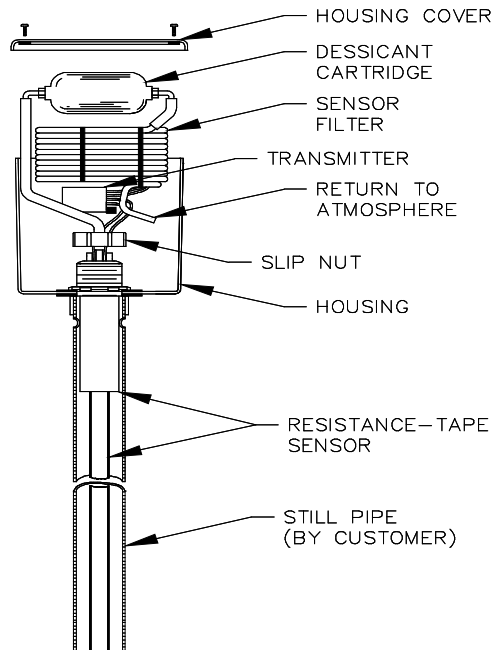

Figure 2 Aquatape Components

#### 4. GAUGE COMPONENTS SUPPLIED

Components of Aquatape Gauging System, Type AGS, as shown in Figure 2, and include:

- \* **Aquatape water-level sensor**, Type AGS/L, where L is overall sensor length in integral feet or integral meters;
- \* **Sensor filter**, Type AGS/SF55, for equalizing atmospheric pressure and protecting sensor interior and electric contacts;
- \* **Sensor housing**, Type AGS/SH666, of molded vinyl (PVC) and 6x6x6 inch envelope dimensions, for containing sensor head, filter, transmitter and wiring connections;
- \* **Transmitter**, Type T-800L, providing 4-20 mA output, and adjustable for sensor lengths (Spans) of 3 to 50 feet or 1 to 15 meters; Type T-800LT, providing 4-20mA output for both level and temperature; or optional alternate resistance transmitter;
- \* **Miscellaneous hardware for gauge assembly.**

## 5. REQUIRED SENSOR CONTAINMENT

Customer must supply a still pipe, or similar containment, to position and protect Aquatape sensor at its measuring location. Fabricated of plastic or metal, the still pipe must be perforated or slotted to allow easy through-flow of gauged liquid or slurry. Representative configurations are shown in Figure 3. An alternate weighted sensor installation method may be used and for this method follow the instructions provide with the weight kit.

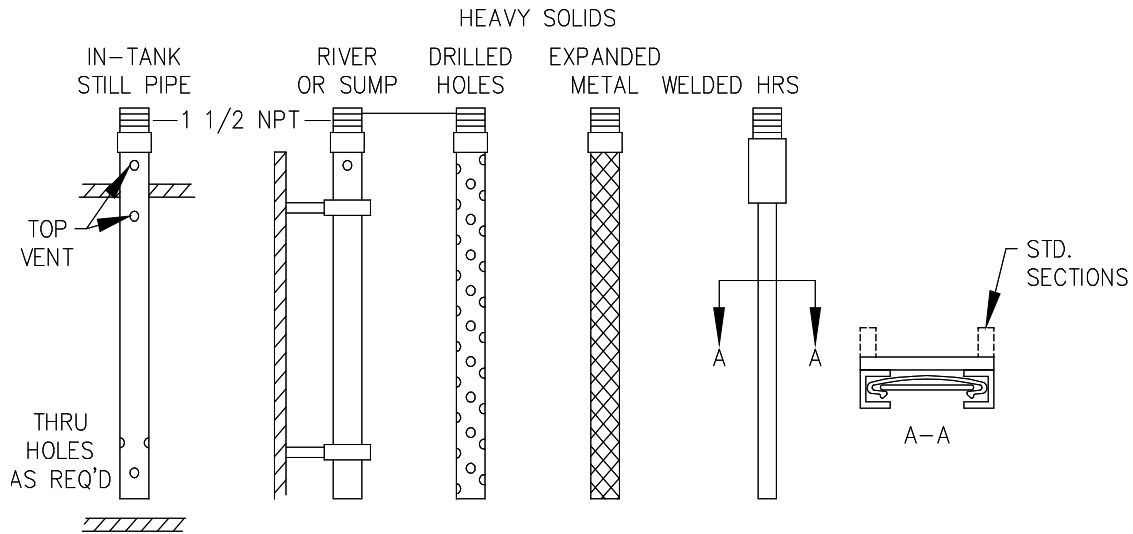

Figure 3 Sensor mounting for various liquid viscosities

For sewage, slurries and viscous liquids, still pipe may be greatly perforated, formed of expanded metal, or fabricated of standard steel channel sections. Requirements for Aquatape still pipe include -

- (a) Still pipe must be 1-1/2" or larger.
- (b) Still pipe must terminate with 1-1/2" NPT thread, which must extend 1-1/2" along pipe in order to conduit lock nuts to tighten properly.
- (c) If still pipe is constructed from 1-1/2" pipe, Schedule 40 pipe must be used. Schedule 80 pipe is unacceptable as the 1.50" I.D. is too small to accommodate the sensor.
- (d) If 1-1/2" PVC Schedule 40 pipe is used, a female socket/male external thread adapter must be used. Schedule 40 PVC pipe is not recommended to be threaded.
- (e) All holes and cuts must be smooth and deburred.
- (f) Pipe top must be located above highest liquid level.
- (g) Pipe must be longer than sensor to provide full protection, 2" is recommended
- (h) Pipe must have top vent hole to prevent air locking.
- (I) Min. 3-foot clearance above Sensor Housing is required for sensor installation.

## 6. ASSEMBLY OF GAUGE

Aquatape Gauging System can be either -

**Assembled in place**, by first mounting still pipe, then adding other components to it. This is appropriate when sensor is ten feet or longer in length, and top of still pipe is accessible at its final operating location; or

**Preassembled** and carried as an integral unit to gauging site, when it is short enough to be so transported. Sensor will be protected in transit by still pipe or other containment, and assembly can then be erected and secured in place with standard hangers or clamps.

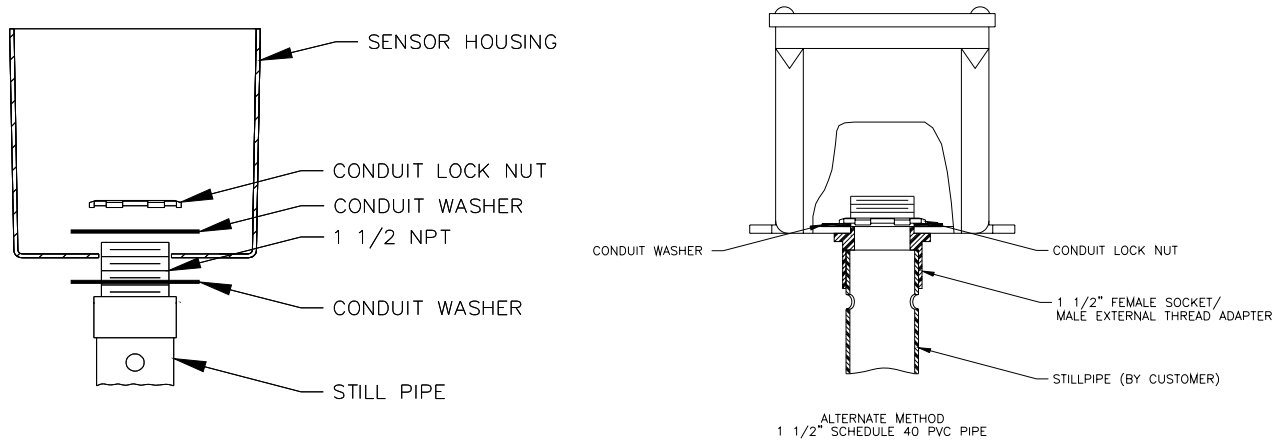

Aquatape components are assembled in the following sequence:

### (a) Sensor Housing

- \* Drill housing to provide cable entrance, within 2" of any vertical edge of the housing, and drain hole in the bottom, as required.
- \* Mount housing to threaded pipe end, as shown in Figure 4. If female socket/male external thread adapter is used at end of still pipe, then only conduit washer and lock nut inside of housing need to be used.
- \* Run locknuts as far onto thread as possible, and tighten to clamp box securely.

### (b) Aquatape Sensor

- \* Check still pipe for proper preparation, and for mounting if already in place.
- \* Make sure that all burrs and sharp edges have been removed.
- \* Have two (2) people available for sensor installation.
- \* Remove packing as you dispense sensor directly from reel into still pipe, as in Figure 5, without bending, twisting or scraping sensor against sharp edges or surfaces.
- \* Secure sensor with plastic ring nut supplied.

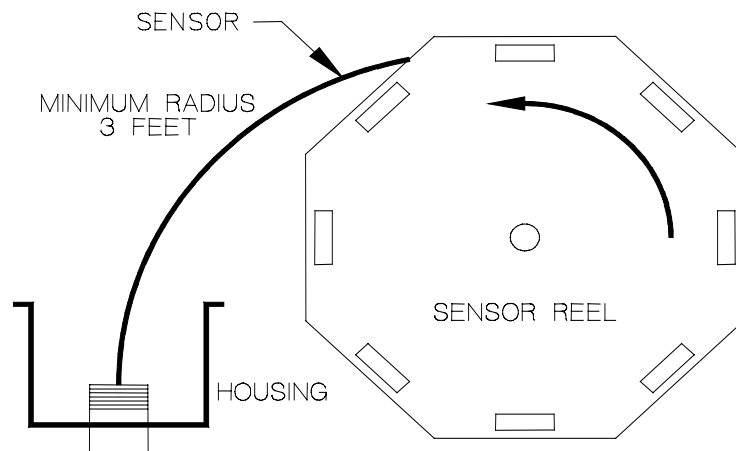

Figure 5 Sensor Installation

### (c) Sensor Filter

- \* Remove protective plugs from sensor breather tube, and from neoprene tubing at cartridge end of filter.
- \* *Immediately* slide neoprene tubing fully onto sensor breather tube, and place filter into Housing without crimping filter tubing.

### (d) Transmitter

**See the T-800 Series Current Transmitter Manual (M323) or other instrumentation manual for alternate equipment supplied.**

- \* *Secure and seal* all connections, *after* completion of calibration and test. Follow standard plant wiring practices, which may utilize crimp connectors, wire nuts, vinyl tape and RTV sealant.

For local or remote level indication, analog and digital meters can be driven by transmitter output. For level readout and adjustable level alarms, see other JOWA Consilium instruments.

## 7. CALIBRATION PROCEDURE

**See the T-800 Series Current Transmitter Manual (M323) or other instrumentation manual for alternate equipment supplied.**

## 8. INSPECTION AND MAINTENANCE

**Filter:** Check every 12 months for continued blue color of desiccant chemicals. If pink or white, replace entire filter with specified part.

**Still Pipe:** Check for silting or other plugging. Is it securely anchored? Damaged?

**Sensor Housing:** Is it clean and dry? Evidence of flooding? If wet, dry out.

**Transmitter:** Is it clean and dry inside? If wet, dry out.

**Field Wiring:** Check for abraded or broken insulation. Are connections sealed, and clean. Repair as required.

## 9. TROUBLESHOOTING

The following will assist in isolating and correcting faulty gauge operation.

**Over-all operation:** Remove box cover, undo ring nut and lift sensor 1 ft. Does output current *fall* by milliamps representing 1 ft? Then lower sensor back in place. Does output *rise* quickly to original value?

**Still Pipe:** If readings lag, check still pipe for open breather hole at top, and unplugged openings at bottom and along pipe length.

**Filter:** Is breather tube open at end of coil? Is connecting tube to sensor free of kinks? To test for plugged filter, note level reading, then momentarily disconnect filter. If level reading changes, filter may be plugged. *Immediately* reconnect filter, or replace with a new one.

**Short circuit:** A short in leadwires will appear as a full tank. A short in sensor allows normal gauge operation down to short location, but not below.

**Open circuit:** An open in leadwires, or at sensor top, produces a level indication below tank bottom (less than 4 mA). An open in sensor helix will not be revealed until liquid level falls below break in helix; operation above break will be normal.

**Transmitter:** Make sure voltage excitation is 20 to 30 Vdc. Check for loose parts or connections. Hook up decade box (Sensor Simulator) in place of sensor, and sweep resistance from 0 to RS ohms marked on tag. Does output go from 20 mA to 4 mA? If so, transmitter is OK; check sensor, still pipe, wiring and filter.

**Sensor:** Remove sensor and check for water penetration; try to locate leak and identify cause (faulty still pipe, careless handling, etc.). If sensor output is jumpy, check for vapor entry at top (due to operation without a filter, or tear in upper jacket, etc.) A damaged or penetrated sensor must be replaced.

**Still puzzled** by Aquatape installation or operating results? Call the JOWA Consilium US Inc. factory. We are here to help you.