

REV	REVISIONS	DATE	APP'D
A	Original Release	11/00	MAP

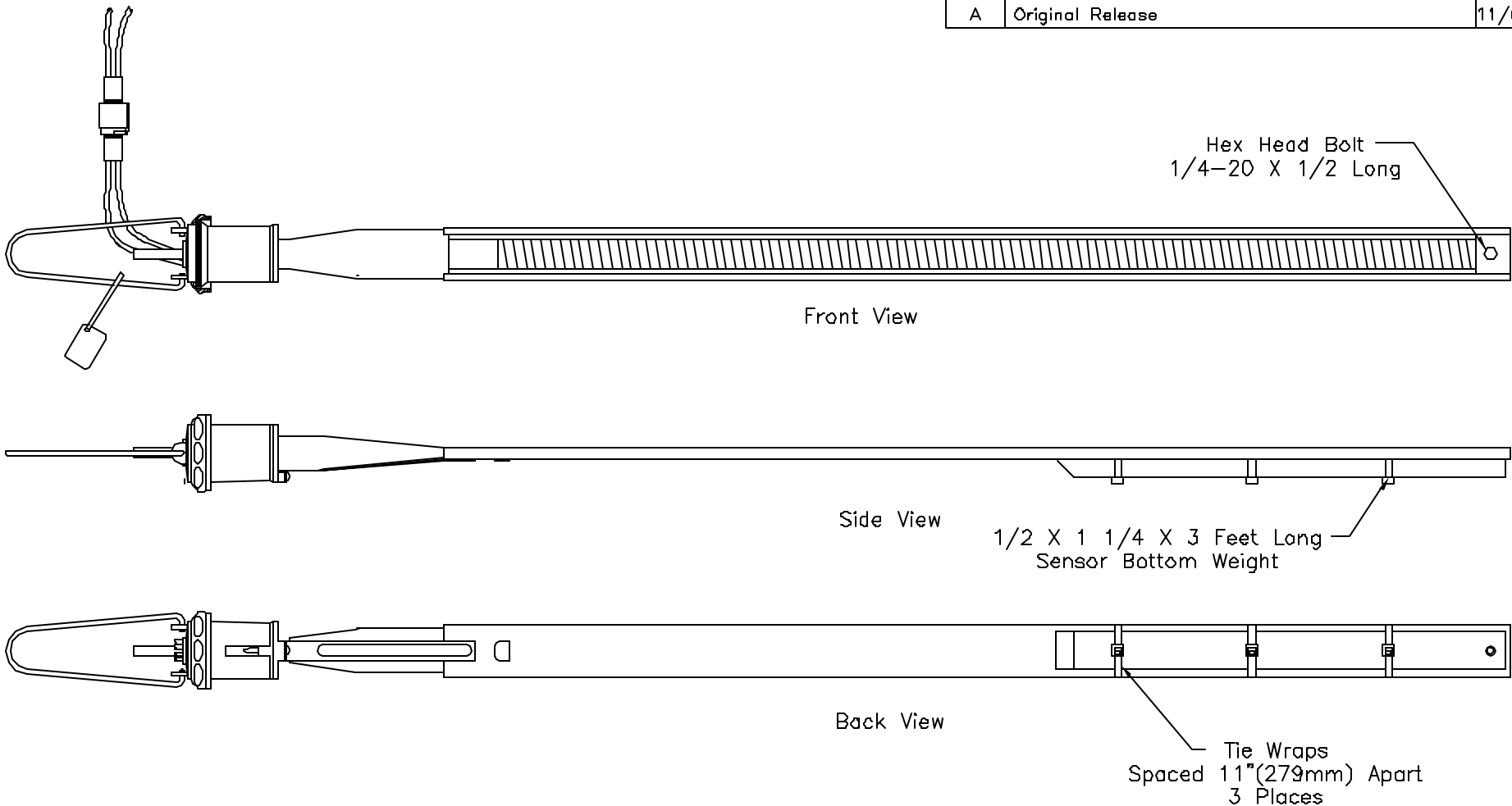

Specifications:

1. Materials: Weight 316 stainless steel or 316 stainless steel TFE coated (optional). Hex head bolt 316 stainless steel or Monel (optional). Tie wraps, Nylon or Polypropylene.
2. Sensor must be installed in a stationary tank. Not for use on boats, trucks or other nonstationary applications. Not for use in applications over 150°F (65°C), tanks over 50 Feet (15 Meters) high (See table on page 2) or with tank cleaning systems.
3. See page 2 for specific tank mounting parameters.

DIMS ARE INCHES [mm] ALL METRIC DIMENSIONS ARE DERIVED FROM INCHES		JOWA Consilium			
Z				Weighted Sensor Specification	
DRN: MAP	5/24/00	A	1923900	REV. A	
CKD:					
NEXT ASSY	USED ON	APPD: MAP	11/29/00	SCALE: NONE	SHEET 1 OF 2

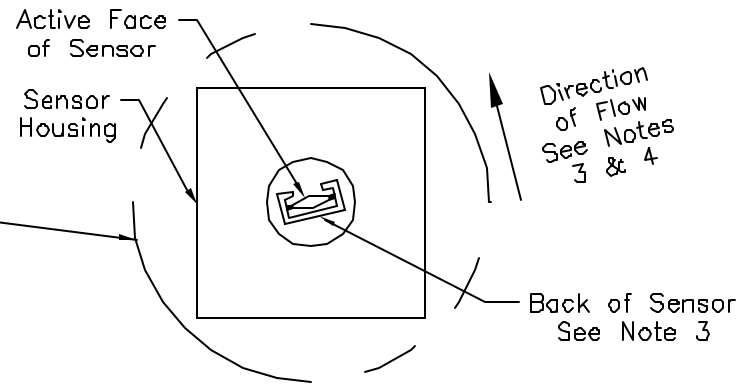
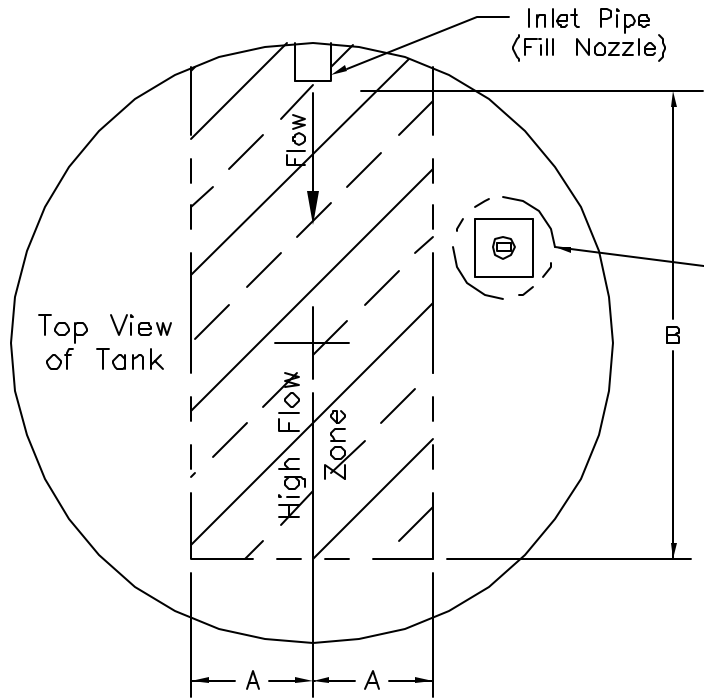

Installation Notes:

1. The weighted sensor is compatible with all Consilium US sensor housings.
2. The sensor housing may be located anywhere on the tank top where the fluid flow under all conditions of filling, discharging, cleaning, etc. is less than 0.1 feet/second (3 cm sec).
3. If the maximum fluid flow rate is not known and is not expected to be excessive, the weighted sensor may be used in a tank if all of the following conditions are met.
 - a) The sensor housing is not located in the high flow zone as dimensioned by the table below and as shown in the figure.
 - b) the height of the tank is less than the maximum allowed in the table below.
 - c) The sensor must be able to move, at the bottom, $\pm 25\%$ of the tank height (front and back) without striking the outlet pipe or any objects within the tank including piping, heating coils, etc.
4. The sensor must be oriented in the housing so that its back surface is in line with the direction of fluid flow.

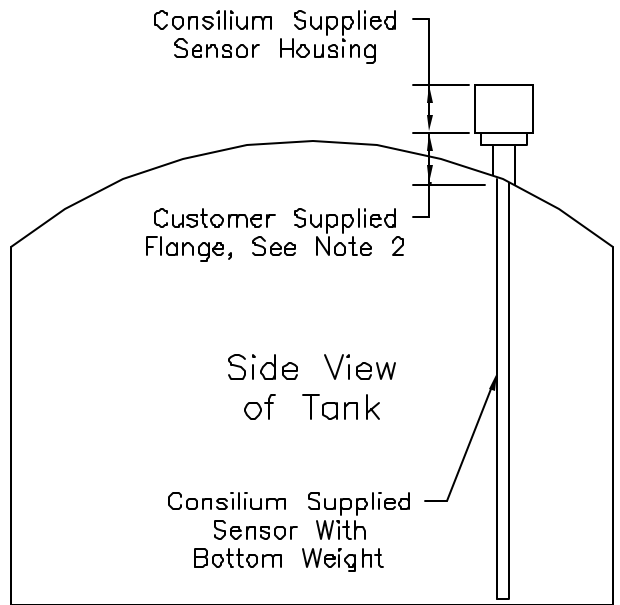

Tank Diameter	Dimension A	Dimension B	Tank Height Maximum
10-19 Feet (3-5 Meters)	4 Feet (1.2 Meters)	N/A	20 Feet (6 Meters)
20-29 Feet (6-9 Meters)	8 Feet (2.4 Meters)	N/A	40 Feet (12 Meters)
30-49 Feet (9-15 Meters)	10 Feet (3.0 Meters)	N/A	50 Feet (15 Meters)
50 Feet Plus (15 Meters)	20 Feet (6.1 Meters)	50 Feet (15 Meters)	50 Feet (15 Meters)

JOWA Consilium		
	A	1923900
		REV. A
SCALE:		SHEET 2 OF 2